

REV	DESCRIPTION OF CHANGE, DWG LOCATION	DATE	APPROVED

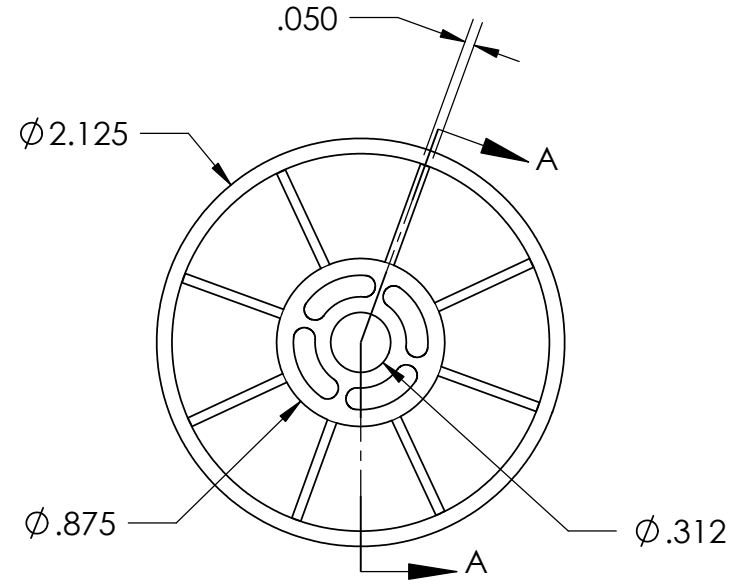
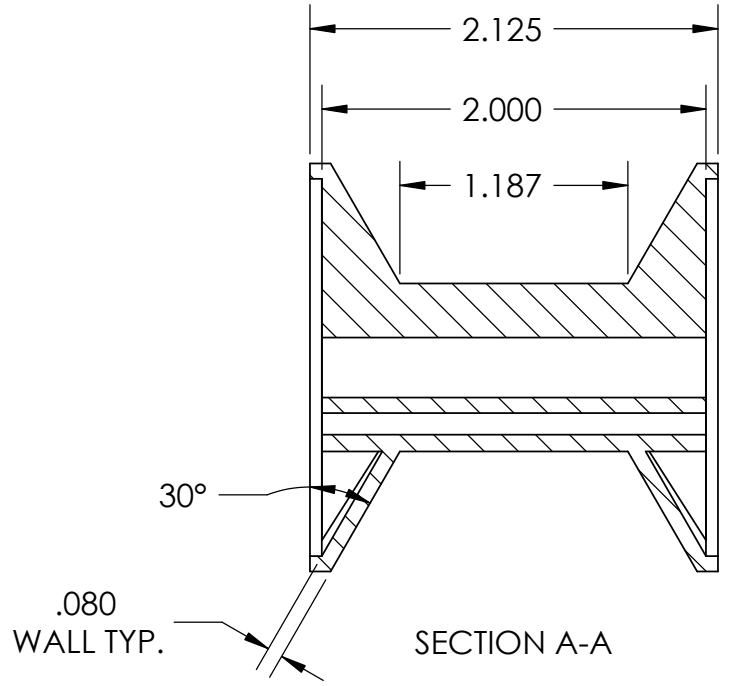
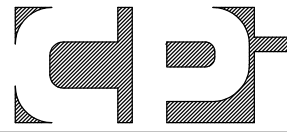

 <b>CAVALLERO PLASTICS INC.</b> 1250 NORTH ST. PITSFIELD MA 01201 PHONE 413-443-0925 FAX 413-443-9586 E-mail sales @cplas.com					PART NAME:	
					B SPOOL (2 OZ)	
TOLERANCE UNLESS SPECIFIED OTHERWISE INCHES					PART #	
.XXXX	.XXX	.XX	.X & FRAC.	ANGLES	PART REV	
± .0010	± .005	± .015	± .12	± 1°	DWG #	
MILLIMETERS					SHEET 1 OF	
				± 1.30	± .40	± 3.0
MATERIAL:					DRAWING BY: <b>BDB</b>	
					CHECKED BY:	
					APPROVED BY:	
					/date	